

innen / inside

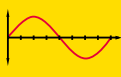

coolant - Kühlmittel

6.3



G Wert - G value

15'000



Drehzahl rpm

Seite / page

10

Preisliste - price list

Hohe Spannkraft



High Force

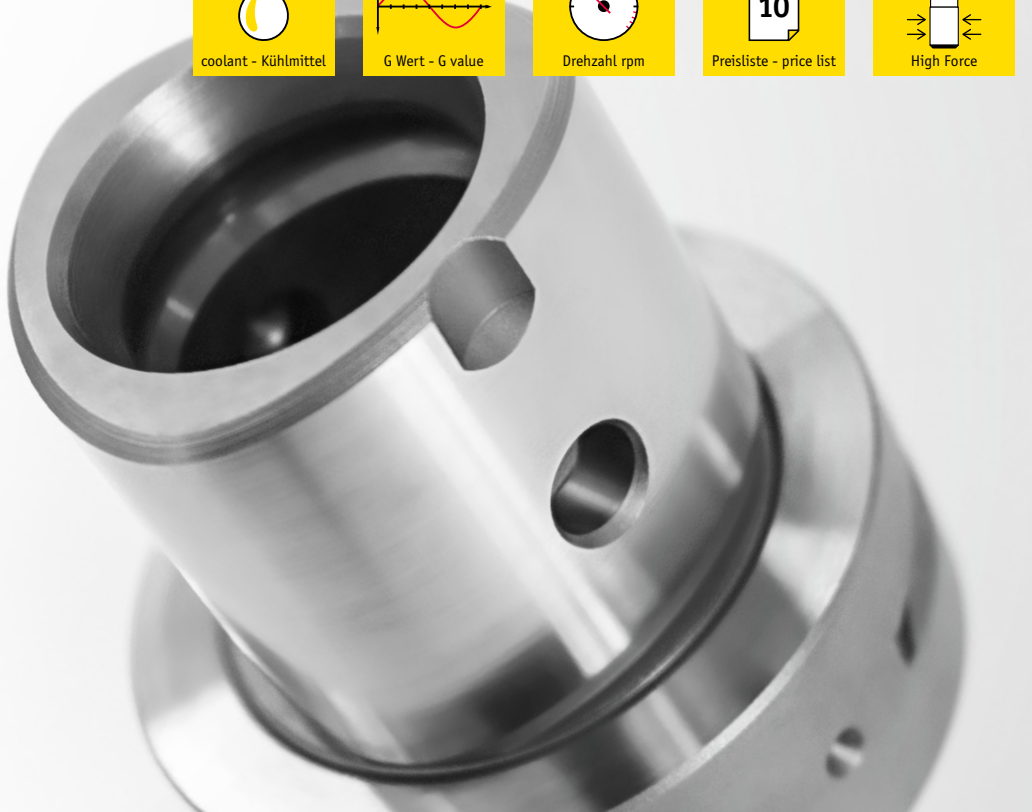

ADAPTO PAX

Adapto-P Einsätze / Polyon Insertion for Adapto P

	Taper No.	Typ Type	Art. Nr. Item no.	Mutter Nut type	d1	D2	D1	L	L1	Max Spann-Ø Max clamp-Ø	VAR	Schlüssel Wrench	Dichtscheiben Sealing Disks
Adapto-PAT	PSG4	APAT-PSG4-060-010	G721 060010	-	10	40	25	60	40	10	1	-	-
		APAT-PSG4-060-012	G721 060012	-	12	40	30	60	42	12	1	-	-
		APAT-PSG4-060-016	G721 060016	-	16	40	35	60	42	16	1	-	-
		APAT-PSG4-060-020	G721 060020	-	20	40	40	60	60	20	1	-	-
Adapto-PAC	PSG4	APAC-PSG4-060-049	G701 060049	RN25	-	40	42	60	35	16	2	9.130.42	-
		APAC-PSG4-060-096	G701 085096	RT16M	-	40	22	85	60	10	3	9.110.16	9.16.XXX
Adapto-PAS	PSG4	APAS-PSG4-070-008	G711 070008	-	6	40	21	70	36	6	4	-	-
		APAS-PSG4-070-010	G711 070010	-	8	40	21	70	36	8	4	-	-
		APAS-PSG4-070-012	G711 070012	-	10	40	24	70	42	10	4	-	-

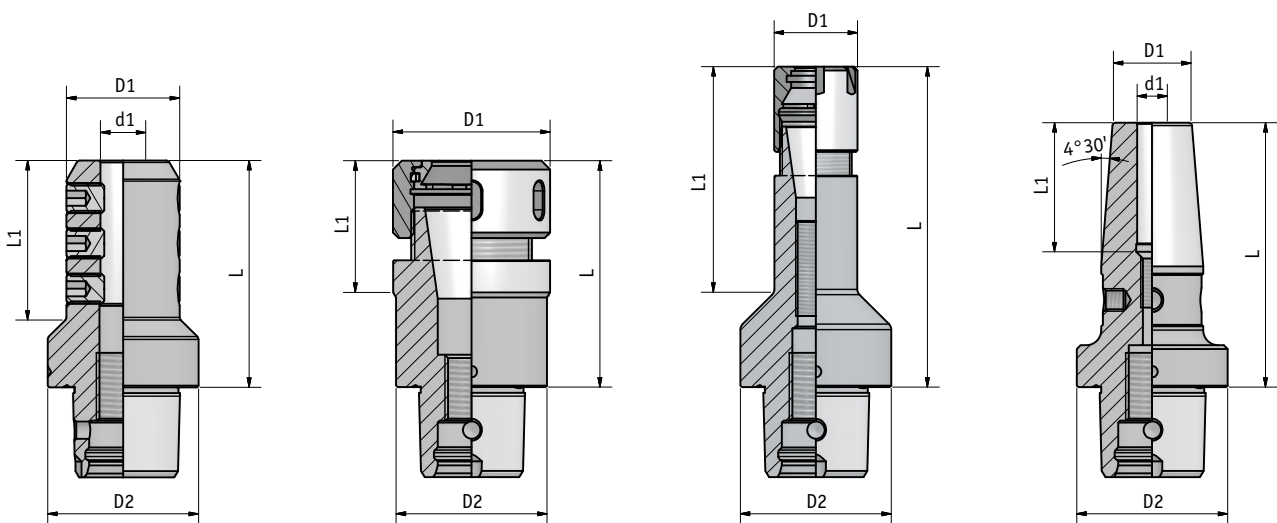

Variante 1



Variante 2



Variante 3



Variante 4